



Lucent Technologies  
Bell Labs Innovations



## ...IEEE 802.11

WaveLAN Sales Bulletin

September 1997

### What is IEEE 802.11 compliance

#### Introduction

Over the past few months there have been rapid developments in the wireless LAN industry which culminated in the recent approval of the IEEE 802.11 standard.

The IEEE Standards board approved the 802.11 wireless LAN standard on June 26th. Lucent Technologies held 2 press conferences on the event, which were well covered by the media. Lucent also issued a press release that is on the WaveLAN web site at: <http://www.wavelan.com>

Many vendors are announcing products or intentions to deliver IEEE product since it's recent approval.

Lucent is working on an IEEE compliant WaveLAN product line. All our competitors are clamoring to deliver IEEE compliant product. They are all trying to be first to the market.

Most of the competitors are using FH technology, though more and more clones come to the market, which are Direct Sequence, because the Harris DSSS chip set gains momentum. The overall industry sees that Direct Sequence is more promising to go to higher speeds, with which Frequency Hopping vendors are struggling. The FH vendors demonstrated interoperability at NetWorld & Interop in Atlanta. Their way to combat the DS vendors (primarily Lucent of course!) The most eye-catching thing was that Proxim was not there.

#### **IEEE 802.11 Committee**

Lucent is committed to the IEEE standard and to providing IEEE-compliant WaveLAN products. Lucent has and continues to lead both the IEEE and European BRAN (Broadband Radio Access Network) standards.

Vic Hayes from Lucent WCND is the Chairman of IEEE and Jan Krays from Lucent WCND is the Chairman of BRAN. Lucent WCND has also been a major contributor to the 802.11 for both the protocol (the Medium Access Control (MAC) layer of the standard) and the transceiver (the physical (DS PHY) layer of the standard).

## Customer requirements

Though few customers are requesting IEEE compliance today in RFP's (Request For Proposal), it is being mentioned so awareness is growing.

Once the standard is published (expected Q3/97) and products are available, awareness will rapidly increase and IEEE 802.11 compliance will become a minimum requirement on an RFP. In addition, though not specifically to do with IEEE, products that incorporate IEEE are newer in design and therefore better in areas such as size, power, cost etc. all which will drive the need for the newer products.

Lucent Technologies and its customers need to be ready for this transition, and the best way to make them ready is to install WavePOINT-II now which provides simple and easy migration to IEEE when products are available.

## What does IEEE 802.11 offer?

---

IEEE 802.11 is a wireless LAN standard that will bring multi vendor interoperability and lower prices. The standard is believed to boost the demand for wireless LAN products in the years to come.

Main features of IEEE 802.11 standard are:

- Robust (because of Acknowledgement, RTS/CTS and fragmentation features)
- Multi channel roaming (allowing multiple cells = higher capacity networks)
- Power management scheme providing longer battery live. (not in first out)
- Automatic rate selection - 2 falls back to 1 Mbit/s, resulting in a connection that stays up longer (FHSS system start at 1Mbps and when the signal is of a sufficient quality they will offer 2Mbps)
- Security WEP (not in the first out)

All major vendors' product lines on the market today are pre-standard. Some vendors claim IEEE compliance today, however this means compliance to a draft version of the standard and not the final version. All vendors require product changes to have IEEE compliance.

Lucent's IEEE strategy is based on its unique dual radio design for the WavePOINT-II. The migration path makes sure that the investments of customers in current WaveLAN products are protected. WavePOINT-II offers a smooth migration path to IEEE compliant products and higher speed technology. See for more information on the migration path WaveLAN Sales Bulletin ... Migration to IEEE 802.11.

## **Opportunity and Threat**

IEEE standard means a paradigm shift for the industry, as everyone will need to move to IEEE compliant products over time. This represents both an opportunity and a threat.

The main opportunity is to gain some of our competitors installed base as people move to IEEE. This is our chance to go back into some of these accounts which we earlier lost and sell Lucent's value. It is also an opportunity to go back into our existing base accounts and upgrade them to our IEEE line. The first step in doing this is WavePOINT-II.

The main threat is that our competitors will be doing the same with our installed base.

## What is IEEE 802.11?

---

IEEE 802.11 is a detailed document issued by IEEE which specifies to vendors how to implement the over the air interface for a wireless local area network product. It can be compared to the Ethernet 802.3 standard, which does the same for Ethernet.

### Over the Air interface

The IEEE standard defines how stations communicated with other stations, and how stations communicate with Access Points. Since all messages travel over air, rather than over cable, the standard is said to define the “over the air” interface.

---

Figure 1 IEEE - A standard protocol over the air

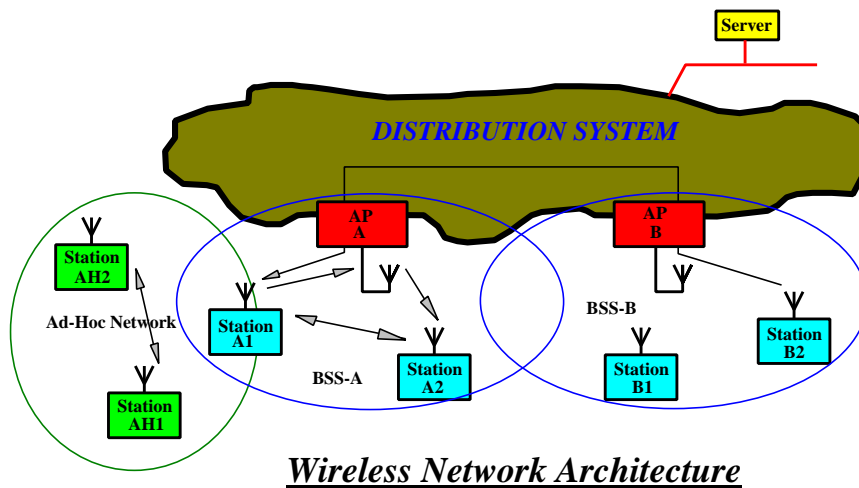

**Figure 2 IEEE 802.11 basics**

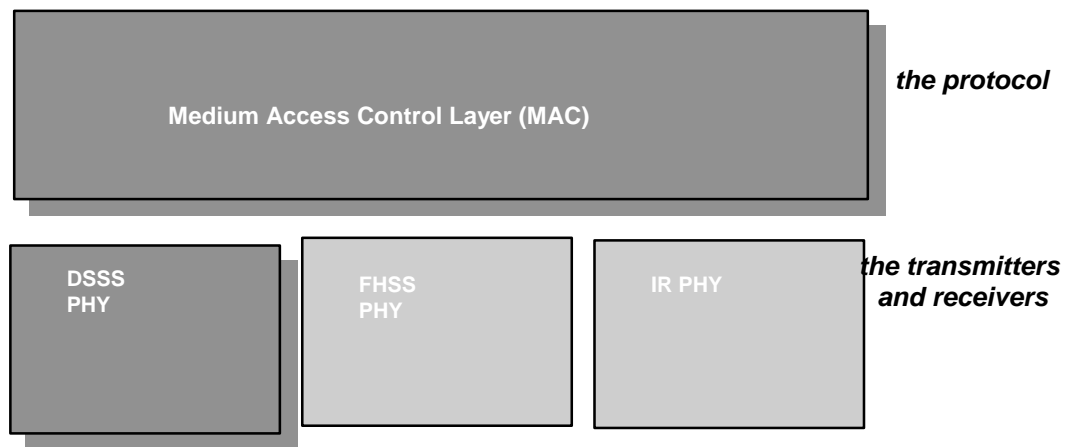

### The PHY

On the physical layer (PHY), below the MAC layer IEEE 802.11 supports 3 different PHY interfaces. These are

- Direct Sequence Spread Spectrum (what Lucent uses)
- Frequency Hopping Spread Spectrum (an alternative)
- Infrared (which only a few vendors are using).

The MAC is common across the 3 PHYs. Again similar to Ethernet which has one MAC (called CSMA/CD) and multiple PHYs (such as 10BASET, 10Base2, 100BASE-TX etc.).

### DSSS PHY- Features

The DSSS PHY is very much like WaveLAN today. Features at a Glance

- 2 Mbit/s raw data rate with a fallback rate to 1 Mbit/s
- QPSK/BPSK modulation
- Barker sequence spreading (11 chips)
- 2.4 GHz band
  - US - 11 overlapping channels
  - ETS - 13 overlapping channels
  - Japan - 1 channel

## The MAC

As with Ethernet, there is a common Media Access Control (MAC) protocol that has been designed and optimized for wireless LAN use. Today in current non-IEEE compliant product, most vendors including WaveLAN use a modified Ethernet protocol. While this works, it is not optimal and does not include provisions for wireless specific functions such as roaming, power management, out-of-range handling etc. In today's products each vendor implements these functions in their own way. The Wireless MAC is designed specifically for wireless systems and takes into account all these features plus more.

### DSSS MAC - Features

Feature	Benefit
CSMA/CA with Acknowledgement	Less impact for lost messages More robust against interference
RTS/CTS	Improved robustness
Wireless Distribution System	Lower investment Improved coverage of the wireless LAN
Automatic Rate Selection	Improves coverage
Multi Channel Roaming	Improves mobility Improved performance
Fragmentation	Higher performance in case of severe noise Easy to cope with intermittent interference (microwave)
Power Management	Save battery life
Encryption based on RC4	Wired Equivalent Privacy (WEP)

### CSMA/CA with Acknowledgement

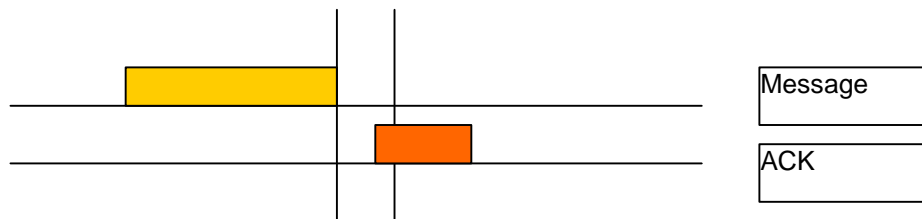

In a wireless system, using the RF medium with all its specific peculiarities, the chance that a message sent from one radio is not received by the radio on the destination end, is larger than in the wired world. To cope with this the Acknowledge was introduced, which means that when the destination receives the message, the receiving radio notifies the sender that the message was successfully received.

If the sender does not receive the ACK, it can take action and retransmit the message. Implementing this recovery mechanism at the MAC layer makes the system very efficient.

By sending this immediately, before any other station gets the chance to grab the medium to start sending the mechanism is fast and costs very little overhead.

The benefit for the user is that the impact of a lost message is not noticeable any more, which means that no hick-ups in the communications will occur and that system is more robust against interference.

### Request To Send/Clear To Send (RTS/CTS) mechanism

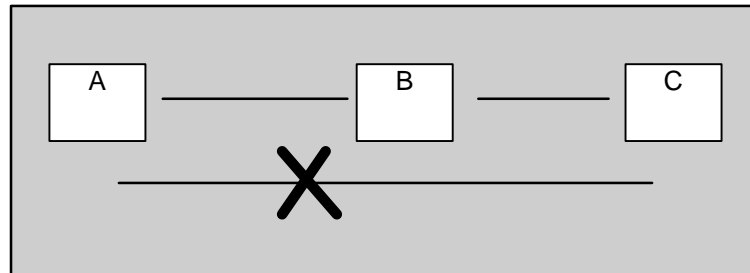

A well known problem in wireless communications is the 'hidden node problem', which can be explained as follows

This can be explained by an example with myself (Station B) and 2 other stations (A and C) standing on one line. The stations A and C cannot hear each other, but I can hear both A and C.

When A starts transmitting to me, it is very well possible that also C will start transmitting, because it is not aware of the fact that A was already sending. This results in neither C nor B being able to understand A

In the 802.11 standard a feature is included to cope with this problem: the 'Request To Send / Clear To Send' (RTS/CTS) mechanism.

To continue the example:

A says to B: 'I'm going to send you data, and it will take 5 minutes'

B says 'everybody quiet for 5 minutes!'

C hears this also, so he will not transmit while A is transmitting. When A stops transmitting, C knows that the air is free.

The benefit for the wireless LAN user is that the RTS/CTS will make the system more robust (against lost messages) and increases the performance of the system

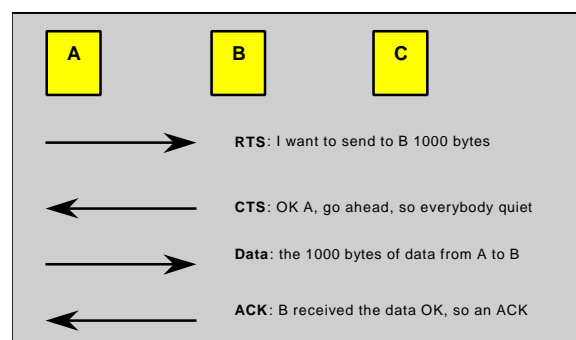

## Wireless Distribution System

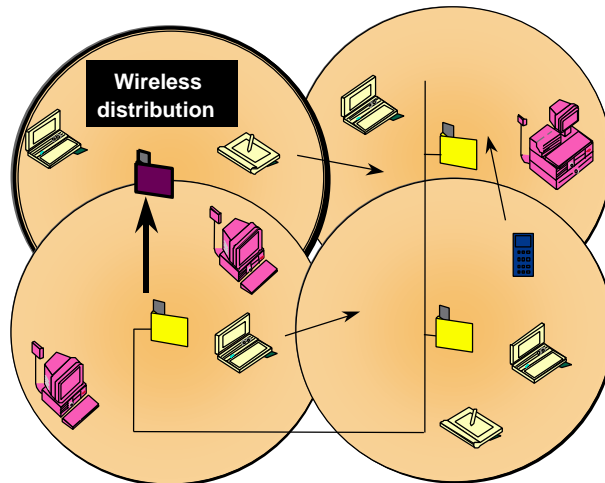

The Wireless Distribution System (WDS) allows you to make a completely wireless infrastructure.

Lucent Technologies WavePOINT-II Access Point already supports a wireless-to-wireless bridge in the current system. Using this feature your organization can create a remote wireless cell without having to pull a wire to the location of the WavePOINT-II, a feature that is often used in large open areas, where it can be very costly to pull a wire.

In the IEEE WDS system there is only one radio needed in the Access Points, supporting both the wireless cell and the connection to another Access Point for a backbone connection,

With WDS your organization needs only one radio in the Access Point, resulting in a cost-of-ownership benefit.



## Automatic Rate Selection

The diagram below shows the benefits of coverage area vs. performance based on the automatic rate selection feature of the WaveLAN IEEE product. Customers can begin with a lower speed mode, requiring less access point each providing greater coverage. As demand for bandwidth increases the customer can simply increase the density of the access points to provide greater throughput. This gives a simple, flexible and cost effective approach to bandwidth management and upgradeability.

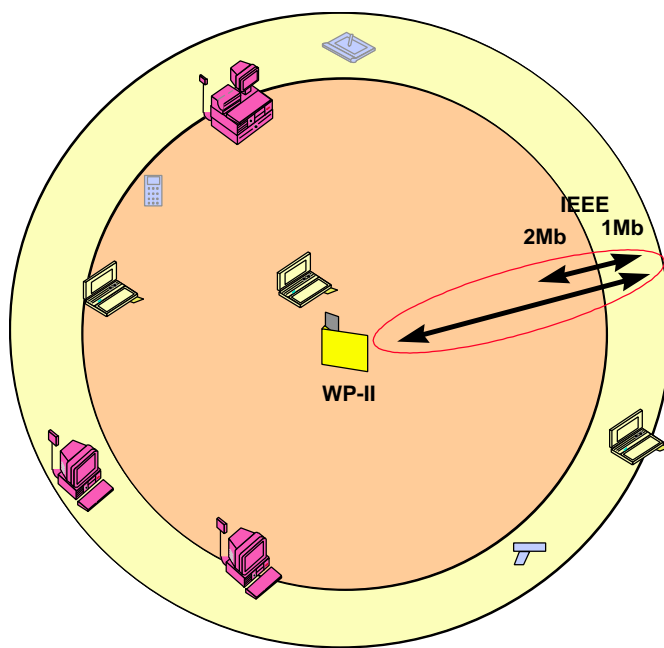

## Multi Channel Roaming

In addition to support for 2Mbps per channel, it is possible to support 3 overlapping channels within the same area. This is because WaveLAN IEEE uses the same IEEE-defined channels, where within the 2.4GHz spectrum, 3 independent channels can be co-located. With roaming support over multiple channels, it is possible to support a combined data rate of  $3 \times 2 \text{ Mbps} = 6 \text{ Mbps}$  total bandwidth available within a given area.

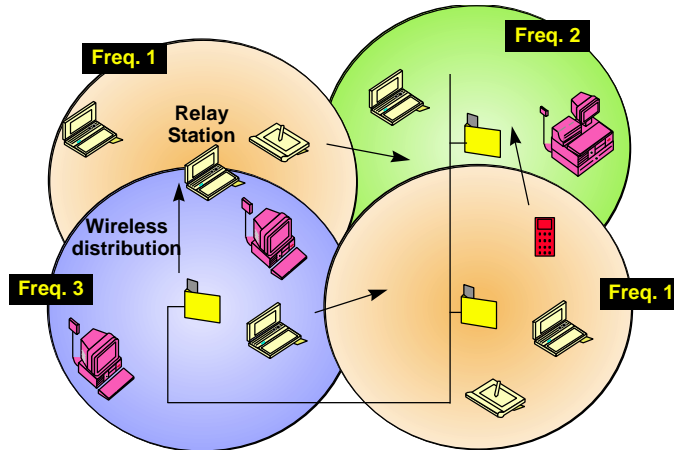

With support for Auto Rate selection, and IEEE compatibility, multiple user environments can be covered with a single backbone infrastructure. In an area requiring high coverage and low throughput (e.g. transaction oriented systems in a warehouse), a low density Access point configuration is cost affective. For those applications requiring higher throughput, (e.g. front office automation), a higher density implementation of Access points can be configured on the same backbone as the warehouse. Users may also roam seamlessly between the two environments.

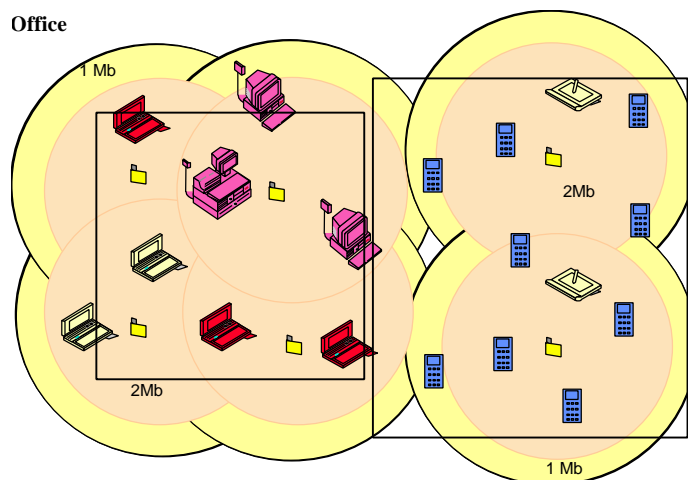

## Message Fragmentation

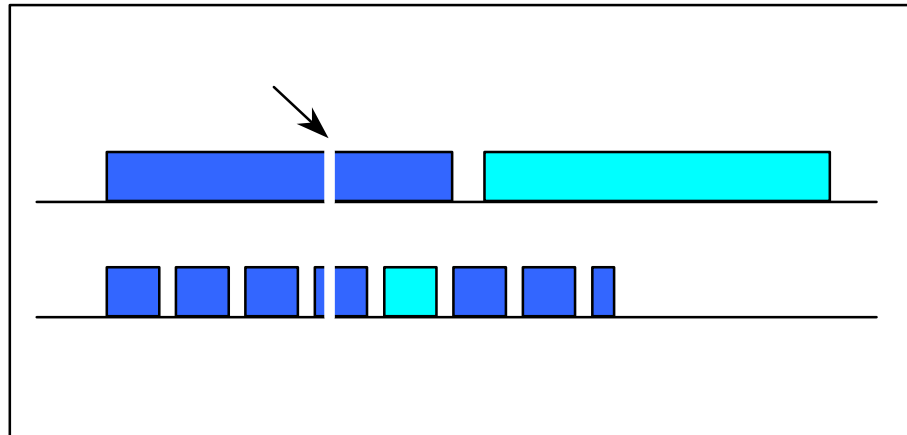

In an environment in which there is interference a chance exists that one or more bits from a message are corrupted. Even if it is only one bit that is corrupted, the complete message needs to be retransmitted.

When there is high interference, with a high probability of bits being corrupted, it makes sense not to send long messages, since retransmission of a short message can be done much quicker.

Another advantage of short messages is the fact that these can be sent in the gaps of an intermittent interferer (e.g. a microwave oven that typically radiated in bursts).

Downside to sending shorter messages is that it takes more overhead. So, in case no bits are corrupted the time to send all the shorter messages is longer compared to the time needed to send only one long message.

The IEEE 802.11 implementation made fragmentation a configurable feature, so the customer is able to use it for messages larger than a certain (configurable) threshold.

Benefit for the customer is that a more robust system can be created in situations of high or intermittent interference

## **Power Management**

Using a mobile system, battery life is always an important factor. IEEE recognized this and included a power management scheme that allows the mobile client to go in sleep mode to save power, with losing the connection to the network infrastructure.

The Network Interface Card in a mobile station goes in sleep mode when there is nothing to send. Incoming messages that are sent when the station sleeps are stored in the Access Point.

In a regular Traffic Information Message (TIM) the Access Point lets the stations know whether there are any messages stored and for whom. All that the stations have to do, is to wake up for a short period to hear the TIM message and act upon that. When there are no messages they can go to sleep again or stay awake when something is stored.

Benefit of this IEEE 802.11 power management is the improved battery life, which will give the customer a longer period of operation.

## **Wired Equivalent Privacy**

The IEEE 802.11 standard includes an encryption mechanism in the MAC, a security level equal to that of a wire. This mechanism is called the Wired Equivalent Privacy (WEP). WEP is based on the RC4 encryption algorithm, an already widely used method of encrypting bit streams.

WEP is available in the WaveLAN IEEE system as an option and offers the customer the security he needs in his wireless network.

## **More benefits**

---

### **Assurance of a technical well defined standard**

The IEEE 802.11 standard has taken 7 years from start to finish. The group membership is comprised of developers, vendors, end-users, & professors representing some 40 different organizations. This type of membership assures that the standard is well defined technically while at the same time meeting the customer requirements. It is designed for high performance in-building wireless usage including mobility and roaming.

The well-known saying of "You never get fired for buying IBM" applies here. IEEE is a well-known and well-respected organization. If they say the standard is good, it is. As a reference the 802.11 committee itself as of the time of this writing includes 58 voting members representing some 40 vendors industry-wide.

This means that a customer can rest assured this has industry wide acceptance and also limits a customer's risk in buying a certain vendor's product. If for example, such a vendor goes out of business, they can simply purchase another vendor's product.

### **Interoperability**

Interoperability amongst the SAME PHY is provided by the standard. This means that an IEEE DSSS can talk to an IEEE DSSS and an IEEE FHSS can talk to an IEEE FHSS. A DSSS cannot talk to an FHSS as they use completely different modulation schemes.

Vendors are working together (including Lucent) to test out their products as they come available to ensure that the interoperability promised by the standard is really there.

### **Decrease costs**

Standards also help to drives costs (=prices) lower, as components become standardized and used across many product, economies of scale kick in resulting in lower costs.

## Summary

---

IEEE 802.11 will improve the awareness and the acceptance of wireless LAN Technology to End Users as a reliable technology for applications is their network infrastructure.

The IEEE 802.11 standard will provide vendor interoperability "over the air" between vendors of the same technology making customers more independent of a wireless LAN vendor. This means both an opportunity and a threat.

Current developments within the IEEE 802.11 committee show that Direct Sequence Spread Spectrum technology provides a better (even the only) migration path to higher speed technology, like Bell Labs DS-PPM (Direct Sequence-Pulse Position Modulation) patented technology.

Main features of IEEE 802.11 standard are:

- Robust (because of Acknowledgement, RTS/CTS and fragmentation features)
- Multi channel roaming (allowing multiple cells = higher capacity networks)
- Power management scheme providing longer battery live. (not in first out)
- Automatic rate selection - 2 falls back to 1 Mbit/s, resulting in a connection that stays up longer (FHSS system start at 1Mbps and when the signal is of a sufficient quality they will offer 2Mbps)
- Security WEP (not in the first out)

The WaveLAN product line will have as key differentiates (above other IEEE products):

- High coverage (due to excellent receiver sensitivity)
- Robust for echoes (so can work better in larger areas e.g. warehouses)