

User's Guide

Nokia is a registered trademark of Nokia Corporation, Finland.

© 1998 Nokia Mobile Phones. All rights reserved.

Nokia Mobile Phones operates a policy of continuous development. Therefore we reserve the right to make changes and improvements to any of the products described in this guide without prior notice.

Issue 1

9351770

Important Safety Information



FOR YOUR SAFETY

Read and follow all warning notices and instructions included in the sales package, in this User's guide and marked on the product itself. Breaking the rules may be dangerous or illegal. Further detailed information is given in this User's guide.



CONNECTING TO OTHER DEVICES

When connecting to any other device, please refer to its documentation for detailed safety instructions. Do not connect incompatible products.



MAKE BACKUP COPIES

Remember to make backup copies of all important data.



QUALIFIED SERVICE

Only qualified service personnel must repair equipment.

INSTALLATION

Follow the installation instructions. Use only approved accessories.



INTERFERENCE

All radio transmitting devices may at times incur interference which could affect performance.



EMERGENCY CALLS

This terminal like any wireless device, operates using radio signals, wireless and landline networks, as well as user-programmed functions which cannot guarantee connection in all conditions. Therefore, you should never rely solely upon any wireless device for essential communications (e.g. medical emergencies).

Contents

| | | | |
|---|-----------|---|-----------|
| Important Safety Information | 2 | 8. Accessories..... | 13 |
| 1. Introduction..... | 4 | 8.1 Backup battery | 13 |
| 2. Sales package contents | 5 | 8.2 External antenna | 13 |
| 3. Putting terminal into use | 6 | 8.3 Data packages | 14 |
| 4. Daily use..... | 7 | 9. Troubleshooting..... | 15 |
| 4.1 Making and receiving calls..... | 8 | 9.1 First things to check | 15 |
| 4.2 Voice mail and Short Message Service (SMS)..... | 8 | 9.2 Dial tone errors..... | 15 |
| 4.3 Supplementary services | 9 | 9.3 Light indicators | 17 |
| 5. Use with fax..... | 10 | 9.4 Error situations with fax..... | 18 |
| 6. Use with computer..... | 11 | 9.5 Error situations with data | 18 |
| 7. Use with other external devices | 12 | 10. Important safety information | 19 |
| 7.1 Display for Calling Line Identification..... | 12 | 10.1 Operating environment | 20 |
| 7.2 Display for Charge Advice Information..... | 12 | 10.2 Emergency calls..... | 20 |
| | | 11. Care and maintenance | 21 |
| | | 12. Technical specifications | 22 |

1. Introduction

Nokia PremiCell is the way to get telecommunication services even to premises where landline phones cannot reach but where there is adequate cellular phone coverage.

Phone calls are transmitted via GSM cellular network, so there is no need for landline connections. With Nokia PremiCell it is also possible to send faxes and make data calls with a computer.

Using the Nokia PremiCell is simple. Just attach the terminal to the wall and connect the power supply. Connect the normal landline telephone to it, lift the handset and make a call as with any other telephone.

The cellular device (Nokia 09i/18i PremiCell) described in this guide is designed to be used as an end-user terminal in GSM 900/ GSM 1800 networks. For information about different network services operational in GSM networks, please consult your network service provider.

2. Sales package contents

The sales package contains the PremiCell terminal, power supply, plug-in antenna, cover for the SIM card, user's guide (this document) and installation kit (screws).

'Nokia 09i/18i PremiCell with Data' sales packages include also a modified SIM card cover, a data user's guide and an AFW-3 data adapter.

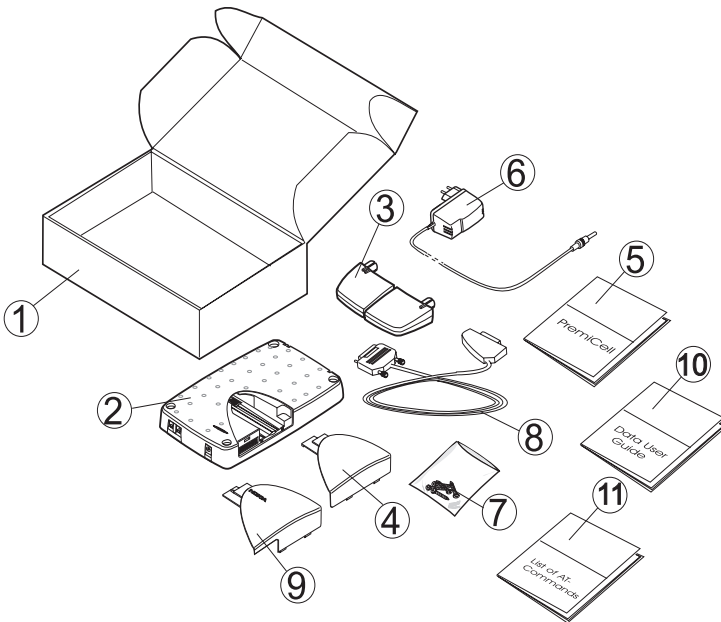

1. Sales package
2. PremiCell terminal
3. Antenna
4. SIM card cover
5. User's guide
6. Power supply
7. Installation kit (screws etc.)

8. AFW-3 data adapter*
9. Modified SIM card cover*
10. RS232 Data user's guide*
11. List of AT-commands*

* Included only in Nokia PremiCell with Data sales packages.

Picture 1. Contents of Nokia PremiCell 09i/18i sales package

3. Putting terminal into use

If your network service provider has not installed your PremiCell terminal, consult the installation procedure in the separate booklet that came with the sales package.

Note: All radio transmitting devices send signals which may cause interference on different electronic devices (telephone set, television, computer, etc). This may lead to a disturbing noise. To avoid this, please install the terminal far enough from other electronic devices (picture 2).

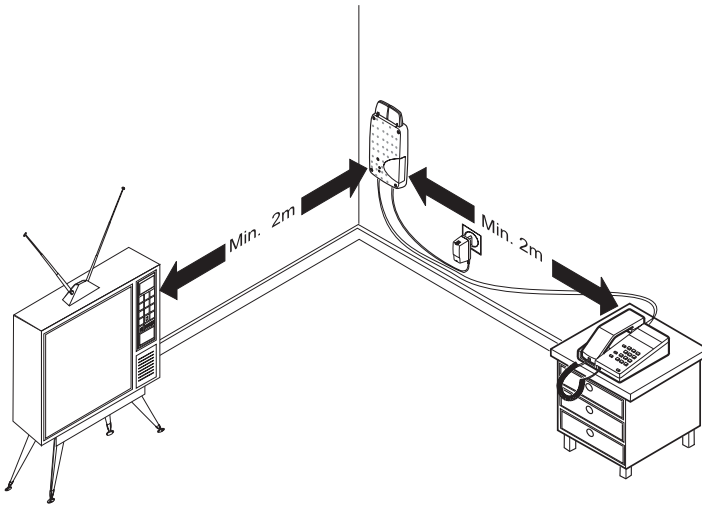

Picture 2. Recommended distances from the PremiCell 09i/18i terminal (A suitable distance is 2 meters. However, not all devices are sensitive to the interference. If no disturbing noise exists, the distance can be shorter.)

It is possible to use three (3) telephones in parallel with the PremiCell terminal. In this case the telephone cord can not be longer than 200 m. If there is only one telephone connected the cord may be 500 meters long. For further information, please contact your network service provider or your local dealer.

4. Daily use

In daily use the terminal concept consists of the following items: PremiCell 09i/18i terminal, and power supply (picture 3). A backup battery is an optional accessory for the terminal. For more information on Nokia PremiCell accessories, see chapter 8.

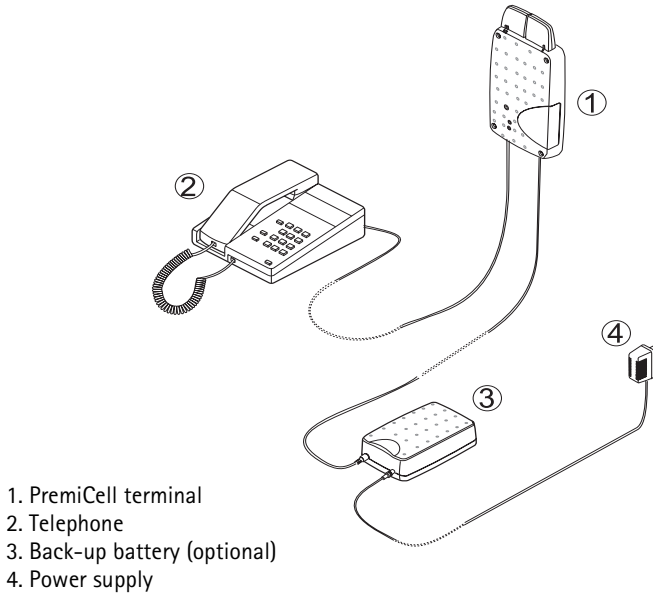

Picture 3. Nokia PremiCell in daily use (with optional backup battery)

4.1 Making and receiving calls

Once the power supply is connected, the transceiver will be switched on and the dial tone can be heard from the telephone. Note that upon first being connected and after a power break, it takes a while before the terminal is connected to the network. If you have any problems, turn to the troubleshooting section (chapter 9).

Dialing and answering the telephone is similar to using a normal telephone. Only the delay in call processing is longer than with a normal telephone due to the internal process of the terminal. Also when making a call, an area code must be dialed both for local calls and long distance calls. Some network systems support local area dialing, i.e. calls can be made without an area code. To find out if local area dialing is supported, consult with your network service provider or local dealer.

Note: As with any other radio transmitting device, avoid unnecessary contact with the antenna.

4.2 Voice mail and Short Message Service (SMS)

Received voice mail is indicated by a broken dial tone (" _ _ _ ") from the telephone handset speaker. Also the second light indicator from the left is on (see figure) When you pick up the telephone handset the light will go off whether the voice mail is listened to or not.

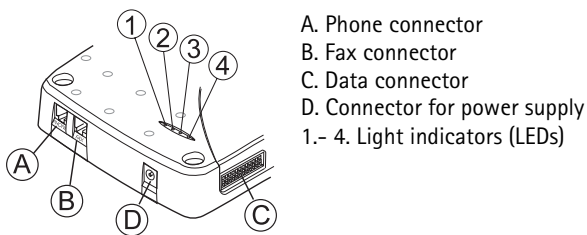

Picture 4. Light indicators and connectors

Usually, the received voice mail can be listened to by calling to your own voice mail box. Ask your network service provider for your own personal voice mail box number.

Received short messages are indicated in the same way as received voice mail (the broken dial tone and the second light indicator from the left). The messages can be read using a suitable computer. In addition, you need the Nokia PremiCell Data Suite package or Nokia PremiCell RS232 Data package to send and read short messages. These accessories are described in section 8.3.

4.3 Supplementary services

The terminal supports the following supplementary services:

- **Call forwarding** (forwards your calls to another number you specify)
- **Call waiting** (alerts you of another incoming call during a phone call)
- **In call handling** (allows you to switch between incoming and active calls)
- **Call restriction** (allows you to restrict outgoing and incoming calls, e.g. international calls)
- **Call transfer** (enables the possibility of connecting two different callers with each other and then disconnect one's own call without disturbing the other two callers)
- **Multiparty call** (with multiparty call (conference call) it is possible to connect several callers into one conversation)

Check with your network service provider for the available services.

5. Use with fax

Fax machine is connected to the "fax" connector of the terminal. The fax machine should be the G3 type that supports data speeds up to 9600 bit/s. Nokia PremiCell doesn't support combi-faxes, i.e. machines that have integrated fax and phone. This is because voice calls cannot be made from the "fax" connector and vice versa.

Note: Although there are separate connectors for telephone and fax, only one of them can be used at a time.

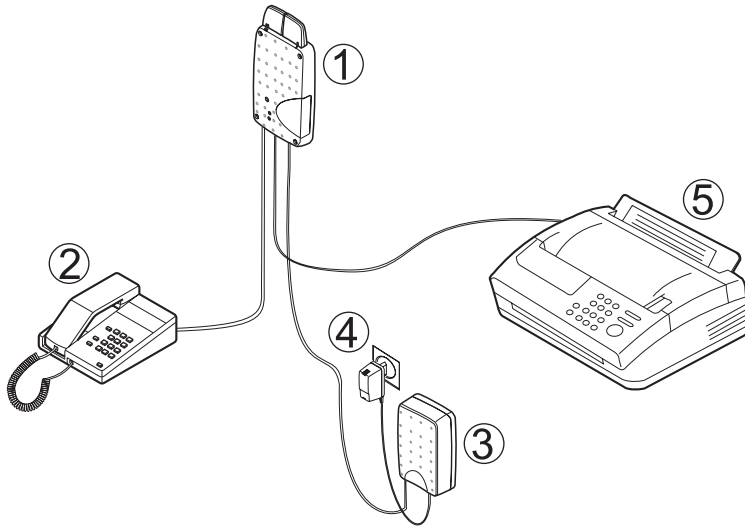

1. PremiCell terminal
2. Telephone
3. Backup Battery (optional)
4. Power supply
5. Fax machine

Picture 5. Nokia PremiCell with a fax machine

6. Use with computer

With the Nokia PremiCell terminal and a suitable computer it is possible to make data calls and send/receive computer faxes. Also Short Message Services (SMS) are available through the computer.

There are two possibilities for connecting a computer to the 09i/18i PremiCell terminal.

- 1) Nokia PremiCell RS232 data package (Data calls, SMS)
- 2) Nokia PremiCell Data Suite Package (Data and fax calls, SMS)

For more information, refer to section 8.3 in this guide and the Nokia PremiCell Data user's guide or the Nokia PremiCell RS232 Data user's guide.

Note: a normal landline modem is not compatible with the terminal, so you cannot connect it to the terminal's 'phone' or 'fax' socket.

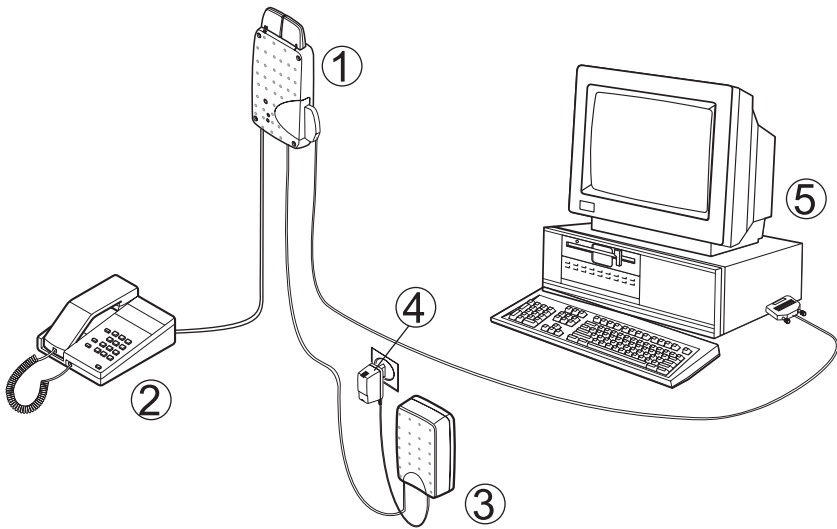

1. PremiCell terminal
2. Telephone
3. Backup supply (optional)
4. Power supply
5. Computer

Picture 6. Nokia PremiCell with a computer

7. Use with other external devices

Two external devices that can be used with Nokia PremiCell are:

- 1) Display for Calling Line Identification (CLI)
- 2) Display for Charge Advice Information (CAI)

Note! CLI and CAI services also have to be supported by the cellular network. For more information contact your network service provider.

7.1 Display for Calling Line Identification

Calling Line Display shows the number of an incoming call. If you have an external calling line display in use, connect it between the telephone and the PremiCell terminal.

There are no Nokia displays available, but there are several manufacturers offering different kinds of displays. Ask for your local dealer for more information.

7.2 Display for Charge Advice Information

Charge advice information shows the costs of the phone calls on an external counter or display. If you have an external counter or display in use, connect it between the telephone and the PremiCell terminal. Please note that costs of data and fax calls cannot be shown in the display or counter. Note also that the actual invoice for calls and services from your service provider may vary, depending upon network features, rounding-off for billing, taxes and so forth.

There are no Nokia displays available, but there are several manufacturers offering different kinds of displays. Ask for your local dealer for more information.

8. Accessories

A range of accessories are available for the Nokia PremiCell terminal. You can select these accessories according to your special communication needs. For availability of the accessories, check with your local dealer. When you disconnect the power cord of any accessory, grasp and pull the plug, not the cord.

IMPORTANT! Use only accessories approved by the terminal manufacturer. The use of any other types will invalidate any approval or warranty applying to the terminal and may be dangerous.

8.1 Backup battery

A backup battery enables calls in situations when the main power fails. The battery backup does not require any user operations after it is connected to the terminal. It is charged directly from the power supply (see picture 3).

The Nokia BBW-1 backup battery can be used with the terminal. The battery should only be used with an ACW-2 (or ACW-3) power supply, which comes with the Nokia PremiCell sales package.

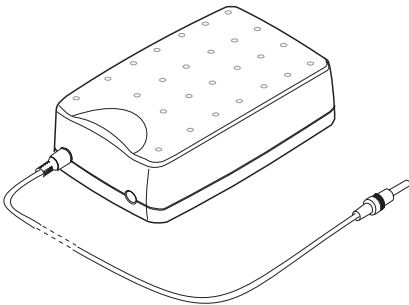

Picture 7. Backup battery

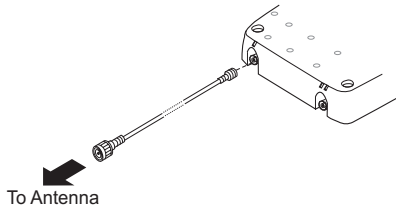

Picture 8. External antenna

8.2 External antenna

If the basic antenna is not sufficient, an external antenna can be used in order to improve signal reception and transmission. There are two alternative types of antennas that can be used with the Nokia PremiCell terminal: (1) window antenna and (2) directional antenna.

If an external antenna is needed, first remove the basic antenna. Then connect the external antenna to the antenna connector marked I. See picture 8.

After installation pick up the telephone handset and dial 333#. You can hear a short beep which indicates that the antenna connector marked with II is disabled. This means that all signals are now going through the external antenna.

If you later want to use the original built-in antenna of your PremiCell terminal, just remove the external antenna, replace the built-in antenna and dial 444#. Again a short beep can be heard from the telephone handset, which indicates that both connectors are in operation.

When selecting an external antenna, please check that both the operating frequency and the gain are suitable:

- Nokia 09i PremiCell: 890 MHz – 960 MHz
- Nokia 18i PremiCell: 1710 MHz – 1880 Mhz

Antenna gain should be over 5dBm. For more information check with your local dealer or network service provider. The antenna connector in the terminal is of mini-UHF type.

Special attention should be paid to the following:

- The antenna should be mounted in such a position that no part of a human body will normally rest too close to any part of it unless there is an intervening metallic screen such as a metallic roof.
- The shorter the antenna cable, the smaller the attenuation and the better the performance of the antenna. The radio equipment must be connected to the antenna by using a non-radiating cable (e.g. coaxial cable).
- If the antenna is directional, direct it towards the nearest base station. Consult with your network service provider.

Note: External antennas are not provided by Nokia. Ask your local dealer or network service provider for more information.

8.3 Data packages

Your PremiCell terminal supports data rates up to 9600 bps. There are two possibilities for making data connections with the terminal. the PremiCell RS232 Data Package and the PremiCell Data Suite Package.

The Nokia PremiCell RS232 Data Package includes:

- A Data adapter AFW-3
- A RS232 Data user's guide
- A List of AT commands
- A SIM card cover (modified for data use)

The Nokia PremiCell Data Suite Package includes:

- A Data adapter AFW-1
- A Data user's guide
- An Installation guide
- Software disks
- A Connecting cable DAU-4F
- A SIM card cover (modified for data use)

Your PremiCell terminal also supports SMS short messages, which can be read and sent using a suitable computer and either of the data packages. Nokia PremiCell data packages are available from your local dealer or network service provider.

9. Troubleshooting

Here are some problem situations you might encounter when using the terminal. If you can't find a solution for the problem, please contact your local dealer or network service provider.

9.1 First things to check

If the terminal is not working properly, make sure that

1. the telephone is connected to the "Phone" connector of the terminal (Picture 9).
2. the power supply is connected to the terminal
3. the antenna is tightly connected to the terminal. Make sure that the antenna is installed as shown in the picture below:

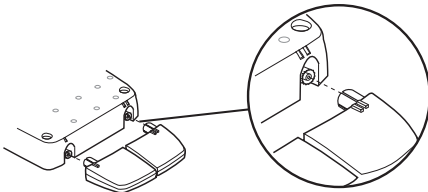

Picture 9. Installing an antenna

Disturbing noise

The terminal is not far enough from the the telephone set or other electronic device (see section 3 in this user's guide).

Disconnections during a phone call

If during a phone call the other party hears disconnections in the speech (sentences or words get 'cut'), the terminal is in poor field strength.

Find a place for the terminal where the radio field strength is adequate. Please refer the separate installation procedure included in the sales package.

9.2 Dial tone errors

If no dial tone can be heard when you pick up the phone:

1. Disconnect and then reconnect the power supply cable from the terminal
Wait for a few seconds until the light indicator (LED 1) has stopped blinking and remains steadily on before you pick up the phone (see section 9.3).

For information on other types of dial tone errors see Table 1.

Table 1. Dial tone errors

| Tone | Explanation | What to do |
|---|---|--|
| ----- | There is no SIM card. | Check that there is a SIM card installed in the cover slot. If there is a SIM card, it might be damaged. Contact your network service provider. |
| - _ _ - _ _ _ - _ _ _ | PIN query | Dial your PIN number and press # . |
| _ _ _ _ _ _ _ _ _ _ | PUK query | Dial your PUK number and press # . |
| ----- | SMS message received (or voice mail). | The tone ends the next time you pick up the phone. |
| There is a "humming" noise in the telephone handset. | The telephone is too close to the PremiCell terminal. | Move the telephone at least 2 meters away from the terminal. |
| Rising tone after dialing the number. | The terminal is not connected to the cellular network. There may be a temporary network problem. | Find a place for the terminal where the radio field strength is adequate. Wait a while. |
| During the phone call the other party cannot hear the conversation. | The terminal is in poor field strength. | Find a place for the terminal where the radio field strength is adequate. |

Note ! If you don't know your PIN or PUK numbers, contact your network service provider.

9.3 Light indicators

There are four light indicators (LEDs) on the lower right hand side of the terminal. From the table below you can check what the states ON, OFF and BLINK indicate.

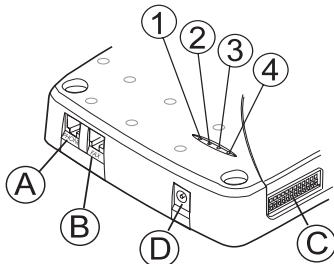

- A. Phone connector
- B. Fax connector
- C. Data connector
- D. Connector for power supply
- 1.- 4. Light indicators (LEDs)

Picture 10. Light indicators and connectors

Table 2. Light indicators

| LED 1 | LED 2 | LED 3 | LED 4 | EXPLANATION |
|-------|-------|-------|-------|---------------------------------|
| - | - | - | - | Power off |
| Blink | - | - | - | Power on, connecting to network |
| On | - | - | - | In service |
| On | On | - | - | Voice mail (SMS) received |
| On | Blink | - | - | Incoming call |
| - | - | Blink | On | PIN query |
| - | Blink | - | On | PUK query (SIM card is blocked) |
| - | - | - | On | Hardware failure |
| On | On | On | On | Self-test |
| - | Blink | Blink | On | Insert SIM card |
| Blink | Blink | Blink | Blink | Contact service |

Note! In case of "Contact service" contact qualified service personnel.

9.4 Error situations with fax

| Situation | Explanation | What to do |
|----------------------------------|--|---|
| Faxes cannot be sent / received. | Using wrong connector. | Check that the fax is connected to the "FAX" connector. |
| Phone doesn't work in combi-fax. | Voice calls cannot be made from "FAX" connector. | |

9.5 Error situations with data

When there are problems with data, refer to the Nokia PremiCell Data user's guide or to the Nokia PremiCell RS232 Data user's guide.

10. Important safety information

The power supply of the PremiCell 09i/18i (see picture 11) converts line voltage of 110V /220V/ 230V AC to low voltage DC.

The power supply ACW-2U with US power plug converts line voltage of 110 V AC to low voltage DC. Use this power supply only in countries and locations where the line voltage is 110 V AC.

Note: The power supply ACW-2U cannot be used with the line voltage of 220V /230 V.

Note: The power supply socket should be easily accessible and it must not be covered. The power supply is insulation class 2 approved.

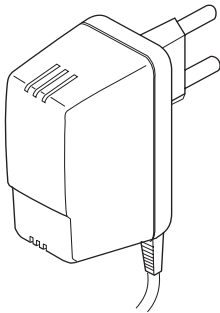

ACW-2
EU 230V

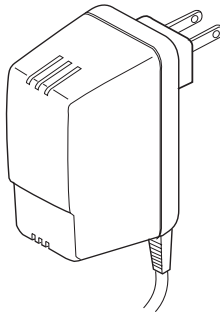

ACW-2P/2U
US 220/110V

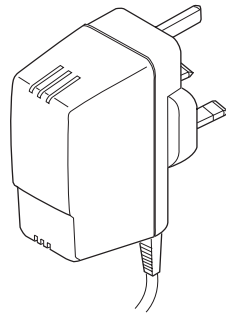

ACW-2X
UK 230V

Picture 11. Power supplies for Nokia PremiCell 09i and 18i terminals

WARNING! Dangerous voltage. Do not attempt to open the casing.

Note! This power supply is for indoor use only ! Do not expose the unit to water, rain or dust.

The power supply should be disconnected from the socket when the terminal is not in use for a prolonged period of time or when the power supply is not connected to the terminal.

When you disconnect the power cord of the power supply, grasp and pull the plug, not the cord.

IMPORTANT! Use only the power supply approved by Nokia. The use of any other types will invalidate any approval or warranty applying to the terminal, and may be dangerous.

10.1 Operating environment

Operation of any radio transmitting equipment, including the PremiCell terminal, may interfere with the functionality of inadequately protected medical devices. Consult a physician or the manufacturer of the medical device if you have any questions. Other electronic equipment may also be subject to interference.

As with other radio transmitting equipment, users are advised that for the satisfactory operation of the equipment and for safety reasons, it is recommended that the equipment should only be used in the normal operating position.

Only qualified service personnel should service the terminal. Faulty service may be dangerous and may invalidate any warranty applicable to the terminal.

Do not cover the terminal.

Do not use the terminal in an environment where strong radiation or magnetic fields may exist. Note that the terminal is for indoor use only.

Failure to observe these instructions may lead to suspension or denial of telephone services for the offender, legal action or both.

10.2 Emergency calls

Remember, to make or receive any calls the terminal must have sufficient power and be properly installed in a service area with adequate signal strength.

Emergency calls may not be possible on all wireless networks or when certain network services and/or product features are in use. Check with the network service provider.

When making an emergency call, remember to give all the necessary information as accurately as possible.

Remember that your terminal may be the only means of communication at the scene of an accident - do not cut off the call until given permission to do so.

Note! Emergency numbers vary in different areas and countries. Check the local emergency number. In some networks, calls to the emergency number may be possible even without a SIM card.

11. Care and maintenance

Your PremiCell terminal is a product of superior design and craftsmanship and should be treated with care. The suggestions below will help you to fulfill any warranty obligations and to enjoy this product for many years. When using the terminal or any accessory:

1. Keep it and all its parts and accessories out of the small children's reach.
 2. Keep it dry. Precipitation, humidity and liquids contain minerals that will corrode electronic circuits.
 3. Do not use or store it in dusty, dirty areas.
 4. Do not store it in hot areas. High temperatures can shorten the life of electronic devices and warp or melt certain plastics.
 5. Do not store it in cold areas. When the terminal warms up (to its normal temperature), moisture can form inside the terminal, which may damage electronic circuit boards.
 6. Do not attempt to open it. Non-expert handling of the device may damage it.
 7. Do not drop, knock or shake it. Rough handling can break internal circuit boards.
 8. Do not use harsh chemicals, cleaning solvents, or strong detergents to clean it. Wipe it with a soft cloth slightly dampened in a mild soap-and-water solution.
 9. Do not paint it. Paint can clog the device and prevent proper operation.
 10. Use only the supplied or an approved replacement or external antenna. Unauthorised antennas, modifications or attachments could damage the terminal and may violate regulations governing radio devices.
 11. When removing the SIM card cover, first disconnect the power supply from the terminal.
- If the terminal or any of its accessories are not working properly, take them to your nearest qualified service facility. The personnel there will assist you, and if necessary, arrange for service.

12. Technical specifications

Transceiver

Dimensions 121x213x28 mm

Weight 800 g

Current consumption (6.8 V)

- Call (1 W) 1200 mA (PremiCell 18i)
- (2 W) 1500 mA (PremiCell 09i)
- Idle 300 mA

Operating time with optional backup battery (3 Ah)

- Stand-by time 10 h
- Talk time 2.5 h (PremiCell 18i)
- 2.0 h (PremiCell 09i)
- Battery voltage 6.8 V nominal

Power supply

Charger type switched mode power supply

AC Mains plug type Europe, UK, US

Input voltage 187–264 V
90–130 V (ACW-2U)

Output voltage 6.8V+/-0.1 V

Output current 1 600 mA (max.)

DC connector 5.5 mm DC plug

Weight 150 g

Volume 100 cm³

Cable length 1500 mm

Environmental specifications

Operating conditions -10° C...+55° C

Storage conditions -40° C...+70° C

Relative humidity range under normal operating conditions 20–75%

The transceiver is not protected against an ingress of water or liquids of any type. Technical specifications are subject to change without prior notice.